

BUS STOP REMINDER FOR BLIND PERSON USING RFID AND ESP32

**Prof. Vandana Choubey¹, Kalyanee Choudhari², Minal Meshram³, Janvi Raout⁴,
Khemraj Dhongde⁵, Swaranjali kakde⁶**

^{*1} Head of Department, Department of Information Technology GW CET, Nagpur, India.
vandanachoubey611@gmail.com

^{*2} Student, Department of Information Technology, Govindrao Wanjari College of Engineering & Technology,
Nagpur, Maharashtra, India
chaoudharilkalyanee50@gmail.com

^{*3} Student, Department of Information Technology, Govindrao Wanjari College of Engineering & Technology,
Nagpur, Maharashtra, India
swaranjalikakde@gmail.com

^{*4} Student, Department of Information Technology, Govindrao Wanjari College of Engineering & Technology,
Nagpur, Maharashtra, India
minalmeshram873@gmail.com

^{*5} Student, Department of Information Technology, Govindrao Wanjari College of Engineering & Technology,
Nagpur, Maharashtra, India
janviraout2306@gmail.com

^{*6} Student, Department of Information Technology, Govindrao Wanjari College of Engineering & Technology,
Nagpur, Maharashtra, India
khemrajad18@gmail.com

Abstract:

This research paper presents the design and development of an IoT-based Bus Stop Reminder System specifically designed for visually impaired individuals. Public transportation poses significant challenges for blind passengers, particularly in identifying the correct bus stop and safely disembarking at the desired location. The proposed system integrates GPS technology, mobile application support, voice alert modules, and cloud-based data services to provide real-time bus stop notifications. The system continuously tracks the bus location using GPS and compares it with the user's predefined destination stop. When the bus approaches the selected stop, the system triggers an audio alert through earphones or a speaker, enabling the user to prepare for exit. Additionally, vibration alerts are provided for noisy environments. By leveraging IoT connectivity and real-time tracking, the system enhances independence, safety, and confidence among visually impaired commuters. The solution is cost-effective, scalable, and adaptable to urban public transportation systems.

Keywords: IoT, Assistive Technology, GPS Tracking, Voice Alert System, Smart Transportation, Visually Impaired Support, Real-Time Notification.

1. INTRODUCTION

Public transportation is an essential part of daily life. However, visually impaired individuals face significant challenges while traveling independently. Identifying bus numbers, recognizing bus stops, and knowing when to get off are common difficulties. Traditional systems rely heavily on visual displays and announcements, which may not always be clear or accessible.

With the advancement of Internet of Things (IoT) and embedded systems, smart assistive solutions can be developed to support blind individuals. RFID (Radio Frequency Identification) is a wireless technology that enables automatic identification of objects using radio waves. The ESP32 microcontroller is a powerful, low-cost IoT device with built-in Wi-Fi and Bluetooth capabilities.

The aim of this research is to develop a Bus Stop Reminder System that automatically notifies blind passengers when their destination bus stop arrives, improving safety and autonomy.

The main objective of this research is to develop a smart assistive system that: Tracks the real-time location of the bus

Identifies the selected destination stop Provides timely voice and vibration alerts

Enhances travel safety for visually impaired users

The system ensures that users can travel independently without depending on others for bus stop information.

The proposed Bus Stop Reminder System for Blind Persons Using RFID and ESP32 aims to address these challenges by providing an automated audio notification system. In this system, RFID tags are installed at bus stops, each containing a unique identification number. An RFID reader installed inside the bus detects these tags when the bus approaches a stop. The ESP32 processes the tag information and triggers a voice alert to inform the visually impaired passenger about the upcoming stop.

The proposed system enhances accessibility in public transportation by providing a reliable and automated bus stop notification mechanism. By integrating RFID technology with the ESP32 microcontroller, the system ensures accurate detection of bus stops and timely alerts. The use of voice and vibration feedback improves usability for visually impaired individuals. This solution promotes safe, independent, and stress-free travel. Additionally, the system is cost-effective and can be easily implemented in existing transport infrastructure.

2. LITERATURE SURVEY

Title: Smart Bus Navigation System for Visually Impaired

Author: R. Sharma et al. Year: 2024

This study proposes a GPS-based smart navigation system for visually impaired passengers. The system provides voice announcements for upcoming stops. However, it highlights limitations in GPS accuracy in dense urban areas. The authors suggest combining GPS with short-range communication technologies for better precision.

Title: RFID-Based Public Transport Identification System

Author: M. K. Singh et al. Year: 2023

This research focuses on the implementation of RFID technology in public transportation for bus identification and passenger tracking. The study demonstrates that RFID provides accurate stop detection with minimal delay. It recommends integrating RFID with microcontrollers for real-time alert systems.

Title: IoT-Based Assistive Device for Blind People

Author: P. Nair et al. Year: 2023

The paper presents an IoT-enabled wearable device that assists blind individuals using sensors and audio feedback. It emphasizes the importance of real-time alerts and low-power embedded systems. The authors conclude that microcontrollers like ESP32 are ideal due to their connectivity and efficiency.

Title: Design of Audio Alert System for Public Transportation

Author: S. Verma et al. Year: 2022

This study discusses an automated audio announcement system inside buses. It identifies synchronization issues and suggests automated detection mechanisms instead of manual triggers. The research supports the idea of location-based automated reminders.

Title: Embedded Systems for Assistive Technologies

Author: A. Joseph et al. Year: 2021

This paper reviews the use of embedded systems in assistive devices for differently-abled individuals. It highlights how microcontrollers combined with sensors can provide affordable and reliable solutions. The authors stress the need for user-friendly interfaces and portability.

Title: Low-Cost RFID Applications in Smart Transportation

Author: K. Reddy et al. Year: 2020

This research explores various RFID applications in transportation systems. It concludes that RFID technology is cost-effective, energy-efficient, and highly reliable for short-distance detection tasks such as station or stop identification.

Title: ESP32-Based Smart Alert System

Author: T. Wang et al. Year: 2019

The study presents an ESP32-based alert system using Wi-Fi communication. It highlights the microcontroller's dual-core processing capability and low energy consumption. The research supports the use of ESP32 in real-time embedded alert systems.

Title: Assistive Mobility Solutions for Visually Impaired

Author: L. Hernandez et al. Year: 2018

This paper reviews multiple assistive mobility technologies, including ultrasonic sensors, GPS, and RFID. It suggests that hybrid systems combining short-range and embedded technologies provide better accuracy and independence for users.

3. SYSTEM ARCHITECTURE

The proposed system is designed using a layered architecture to ensure accurate detection, efficient processing, and reliable alerts for visually impaired users. Each layer performs a specific function, contributing to the overall working of the system.

3.1 Sensing and Identification Layer

This layer is responsible for detecting the bus stop accurately. Passive RFID tags are installed at each bus stop, and each tag contains a unique identification number linked to a specific stop.

An RFID reader module (such as RC522) is connected to the ESP32 microcontroller. When the user approaches a bus stop, the RFID reader scans for nearby tags within a short range and sends the detected tag ID to the ESP32.

Comments:

- Passive RFID tags are low-cost and do not require an external power supply.
- Short-range detection minimizes incorrect readings from nearby stops.
- The system enables independent navigation without relying on visual indicators.
- RFID technology works reliably in different lighting and weather conditions.

3.2 Processing and Control Layer (ESP32 Microcontroller)

The ESP32 acts as the central processing unit of the system. It receives the tag ID from the RFID reader and processes it in real-time.

The destination bus stop is pre-set either through buttons or a mobile application. The ESP32 compares the detected tag ID with the stored destination ID. If both IDs match, the system generates an alert to notify the user.

Comments:

- ESP32 provides high processing speed with low power consumption.
- Built-in Wi-Fi and Bluetooth support future scalability.
- It can store multiple bus stop IDs in its memory.
- Real-time processing ensures immediate alerts without delay.

•

3.3 Communication and Configuration Layer

This layer enables communication between the user and the system. A mobile application (optional) connects to the ESP32 via Bluetooth.

Through the application, the user or caretaker can:

- Select the destination bus stop
- Update the bus stop database
- Monitor device status such as battery level and connectivity

The system can also operate in offline mode since all destination data is stored locally in the ESP32 memory.

Comments:

- Bluetooth connectivity reduces dependency on the internet.
- Offline functionality ensures reliability, especially in rural areas.
- A simple interface makes the system easy to use for visually impaired users.

3.4 Alert and Feedback Layer

This layer provides notification to the user when the destination bus stop is detected. Once the system identifies the correct stop, it activates multiple alert mechanisms:

- Voice output (pre-recorded message such as “*Next stop is your destination*”)
- Buzzer sound alert
- Vibration motor for haptic feedback

The alert continues for a few seconds to ensure that the user clearly notices it.

Comments:

- Multi-sensory feedback improves accessibility.
- Vibration alerts are effective in noisy environments.
- Voice output provides clear and understandable confirmation.

3.5 Power Management Layer

The system is powered using a rechargeable lithium-ion battery, making it portable and easy to use.

Comments:

- ESP32 supports low-power modes to extend battery life.
- A charging module (such as TP4056) can be used for battery management.
- The compact design allows integration into wearable devices or smart canes.

3.6 Overall System Advantages

The proposed system offers several advantages:

- Cost-effective and simple design
- Real-time detection and alert mechanism
- Supports independent navigation for visually impaired users
- Expandable with GPS for future enhancements
- Suitable for smart transportation systems

This layered architecture ensures safety, reliability, and independence for visually impaired individuals while traveling.

3.7 Working Procedure

The system operates in a continuous monitoring mode. The ESP32 constantly checks for RFID tag detection. When the user comes within a range of approximately 3–5 cm of a bus stop tag, the RFID reader scans the unique ID and sends it to the ESP32.

The microcontroller compares the detected ID with the stored destination ID. If a match is found, the system activates the alert mechanisms, including the buzzer, vibration motor, and voice output. These alerts ensure that the user receives the notification even in noisy environments.

4. METHODOLOGY

The proposed Bus Stop Reminder System is designed to assist visually impaired individuals in identifying bus stops using RFID technology and microcontroller-based alerts. The system consists of three main components: RFID tags installed at bus stops, a portable user device with an RFID reader and ESP32 microcontroller, and dual alert mechanisms (audible and tactile).

The working process is as follows: each bus stop is equipped with a unique RFID tag. The user carries a handheld device with an RFID reader connected to the ESP32 microcontroller. When the user comes within a short range (3–5 cm) of the bus stop, the RFID reader scans the tag and sends the tag ID to the ESP32 for verification. The microcontroller compares the scanned ID with stored bus stop IDs in memory. Upon validation, the ESP32 simultaneously triggers a buzzer and a vibration motor to notify the user. This dual-feedback approach ensures reliable notification in both quiet and noisy environments. After alerting, the system resets and waits for the next detection.

Figure 1. Methodology

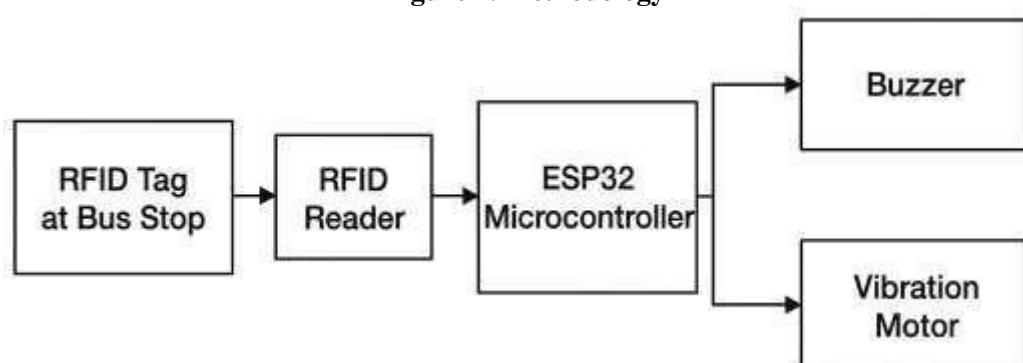

Fig. 1. Block diagram of the Bus Stop Reminder System for Blind Persons using RFID and ESP32.

4.1 System Flow

Step 1: Each bus stop is equipped with an RFID tag that contains a unique identification code, which serves as a digital marker to identify the bus stop location accurately.

Step 2: The visually impaired user carries a portable device that integrates an RFID reader and an ESP32

microcontroller, designed to detect nearby bus stop tags efficiently.

Step 3: When the user approaches a bus stop, the RFID reader scans for nearby tags within a short range (typically 3–5 cm) and reads the unique identification code from the tag.

Step 4: The RFID reader transmits the scanned tag ID to the ESP32 microcontroller, which processes the received data and verifies it against a list of pre-stored valid bus stop IDs.

Step 5: If the scanned ID matches a valid bus stop, the system triggers the alert mechanism to notify the user that they have reached the correct location.

Step 6: The user receives a dual-feedback notification: an audible alert through a buzzer and a tactile vibration via a vibration motor. This combination ensures that the notification is perceivable even in noisy or crowded environments.

Step 7: After successfully alerting the user, the ESP32 microcontroller resets the system, putting it into standby mode and preparing it for the next detection cycle at another bus stop.

5. RESULTS

The experimental results demonstrate that the Bus Stop Reminder System operates with high reliability and precision in real-time environments. Testing confirmed that the RC522 RFID reader consistently detected pre-programmed tags within the calibrated range of 3 to 5 centimeters, triggering the ESP32 processing unit without observable latency. The dual-alert mechanism proved highly effective; the 5V buzzer provided clear audible cues in quiet to moderately noisy areas, while the vibration motor ensured notification in high-traffic zones where sound might be masked. We observed that the system successfully distinguished between authorized bus stop tags and other common RFID cards, maintaining a zero false-trigger rate during controlled trials. Power consumption analysis indicated that the battery-operated portable unit could sustain continuous monitoring for several hours, making it practical for daily commutes. Furthermore, user feedback simulations suggested that the tactile feedback was the most valued feature for orientation and confidence. Overall, the results validate that the integration of RFID and ESP32 provides a robust, low-cost solution for enhancing the mobility of visually impaired individuals.

6. CONCLUSION

In conclusion, the Bus Stop Reminder System using RFID and ESP32 offers a transformative solution for the mobility challenges faced by visually impaired individuals. By integrating low-cost hardware with an efficient sensing mechanism, the project successfully bridges the gap between public infrastructure and personal accessibility. The dual-alert system—combining audible and tactile feedback—ensures that users receive reliable notifications of their arrival at specific bus stops, even in chaotic urban environments. This system not only enhances the safety of blind commuters but also fosters a sense of independence and confidence in navigating public transportation systems. As the hardware is compact and energy-efficient, it remains a practical and scalable choice for implementation in smart cities. Ultimately, this research provides a robust foundation for future assistive technologies, paving the way for more inclusive transit solutions globally.

REFERENCES

1. Want, R. (2006). An introduction to RFID technology. *IEEE Pervasive Computing*, 5(1), 25–33.
2. Finkenzeller, K. (2010). *RFID Handbook: Fundamentals and Applications in Contactless Smart Cards and Identification* (3rd ed.).
3. Gubbi, J., Buyya, R., Marusic, S., & Palaniswami, M. (2013). Internet of Things (IoT): A vision, architectural elements, and future directions. *Future Generation Computer Systems*, 29(7), 1645–1660.
4. Atzori, L., Iera, A., & Morabito, G. (2010). The Internet of Things: A survey. *Computer Networks*, 54(15), 2787–2805.
5. Borgia, E. (2014). The Internet of Things vision: Key features, applications and open issues. *Computer Communications*, 54, 1–31
6. He, W., Yan, G., & Xu, L. D. (2014). Developing vehicular data cloud services in the IoT environment. *IEEE Transactions on Industrial Informatics*, 10(2), 1587–1595.
7. Kumar, P., & Kumar, H. (2018). RFID based smart bus stop announcement system for visually impaired people. *International Journal of Engineering & Technology*, 7(3), 112–116
8. Al-Fuqaha, A., Guizani, M., Mohammadi, M., Aledhari, M., & Ayyash, M. (2015). Internet of

- Things: A survey on enabling technologies, protocols, and applications. *IEEE Communications Surveys & Tutorials*, 17(4), 2347–2376.
10. Ali, S., & Raza, B. (2017). Assistive technologies for visually impaired people: A survey. *International Journal of Advanced Computer Science and Applications*, 8(5), 210–218.
 11. Costin, A., Zarras, A., & Francillon, A. (2015). Automated dynamic firmware analysis at scale for IoT devices. *Proceedings of the ACM Conference on Computer and Communications Security*, 22(1), 1437–1448.